

STRAIGHT FLOATING JACK SOLDER TYPE

R128.297.000

CABLE .141

Series : BMA

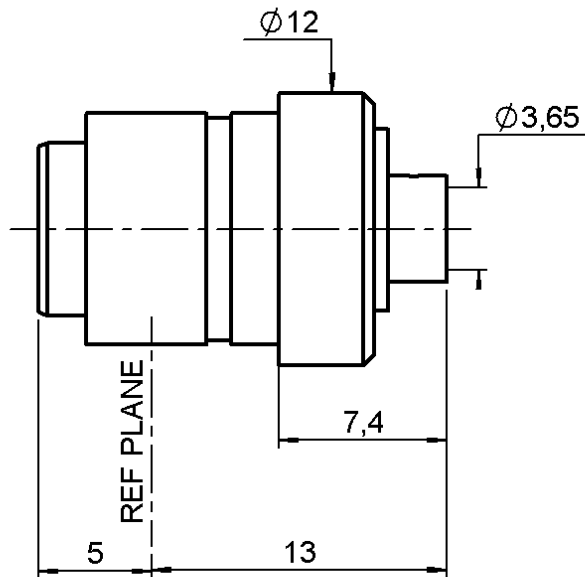

PANEL PERCING

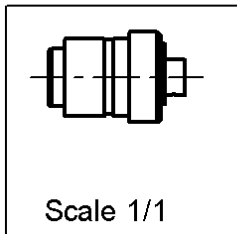
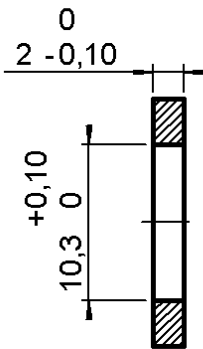

All dimensions are in mm.

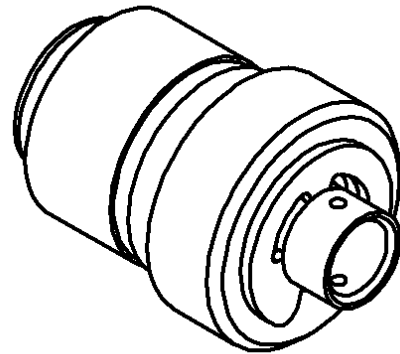

COMPONENTS	MATERIALS	PLATINGS (μm)
BODY	STAINLESS STEEL	GOLD 0.5 OVER NICKEL 2
CENTER CONTACT	BERYLLIUM COPPER	GOLD 1.3 OVER NICKEL 2
OUTER CONTACT	BERYLLIUM COPPER	GOLD 1.3 OVER NICKEL 2
INSULATOR	PTFE	
GASKET	-	
OTHERS PARTS	STAINLESS STEEL	PASSIVATED .
-	-	-
-	-	-

Issue : 0049 B

In the effort to improve our products, we reserve the right to make changes judged to be necessary.



STRAIGHT FLOATING JACK SOLDER TYPE

R128.297.000

CABLE .141

Series : **BMA**

PACKAGING

Standard	Unit	Other
100	'W' option	Contact us

SPECIFICATION

CABLE ASSEMBLY

ELECTRICAL CHARACTERISTICS

Stripping	a	b	c	d	e	f
mm	2.16	0.00	0.00	0.00	0.00	0.00

Impedance		50	Ω
Frequency		0-22	GHz
VSWR	1.05 +	0.010	x F(GHz) Maxi
Insertion loss		0.03	\sqrt{F} (GHz) dB Maxi
RF leakage	- (NA	- F(GHz)) dB mini
Voltage rating		500	Veff Maxi
Dielectric withstanding voltage		1500	Veff mini
Insulation resistance		5000	M Ω mini

Assembly instruction :

Recommended cable(s)
KS 2
RG 402

Cable retention

- pull off **272** N mini
- torque **NA** N.cm

MECHANICAL CHARACTERISTICS

TOOLING

Center contact retention			
Axial force – Mating end		27	N mini
Axial force – Opposite end		27	N mini
Torque		NA	N.cm mini

Part Number	Description	Hexagon
.	.	.
R282.740.000	SOLDERING MOUNTING	
R282.860.100	SOLDERING POSITIONER	
R282.053.000	STRIPPING TOOL	
R282.066.000	POINTER GAUGE	

Recommended torque			
Mating		NA	N.cm
Panel nut		NA	N.cm
Clamp nut		NA	N.cm
A/F clamp nut		0.000	mm

OTHERS CHARACTERISTICS

Mating life		1000	Cycles mini
Weight		0.000	g

ENVIRONMENTAL

Operating temperature		-65/+125	$^{\circ}$ C
Hermetic seal		NA	Atm.cm3/s
Panel leakage		NA	

Issue : **0049 B**

In the effort to improve our products, we reserve the right to make changes judged to be necessary.



STRAIGHT FLOATING JACK SOLDER TYPE

R128.297.000

CABLE .141

Series : BMA

COMPONENTS

BODY

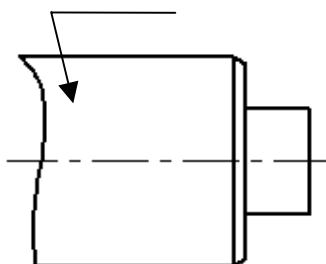

STIPPING DIMENSIONS

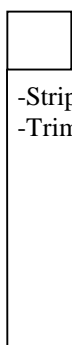
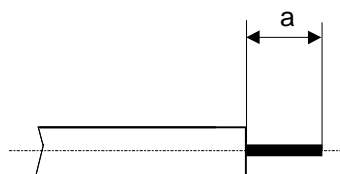

- Strip the cable with the cable stripping tool.
- Trim the cable inner conductor with the trimmer.

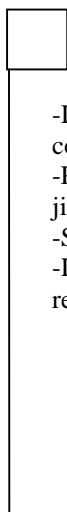
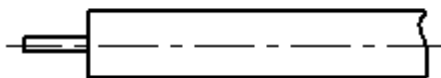

- Introduce the cable into the body until contact with the body shoulder..
- Place the sub-assembly on assembly jig
- Solder body on the cable.
- Let assembly cool down before removing it from the jig.

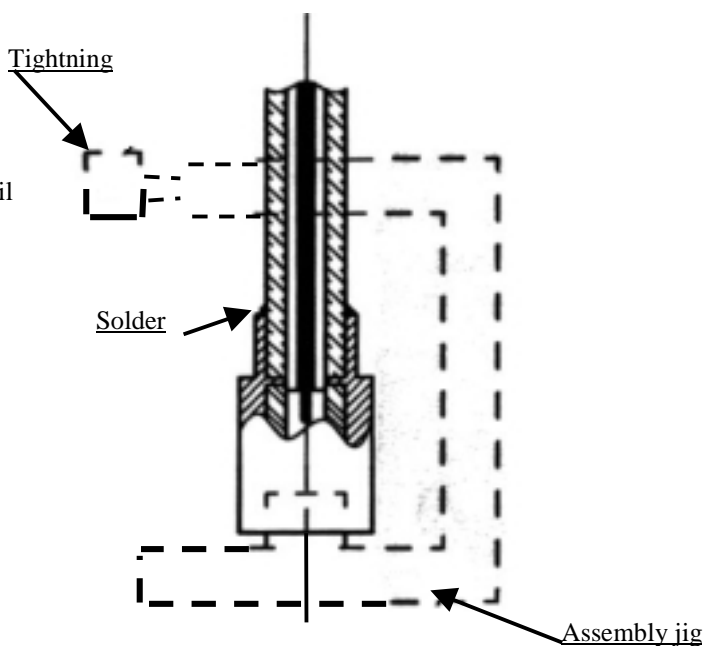

Issue : 0049 B

In the effort to improve our products, we reserve the right to make changes judged to be necessary.

